



USER MANUAL

K-9 LIGHTS BULLDOG

LED PAR64

RGBW



Index

Introduction	3
Safety Instruction.....	3
Fixture Diagram	4
Features.....	4
DMX Control	5
Display	7
Menu	8
Connecting Fixtures	10
Optional Accessories.....	11
Technical specification.....	12

Please read over this manual before operating the light

Introduction

Thank you for purchasing the K-9 Bulldog LED PAR64 fixture. Please read these instructions carefully before using or operating the fixture to avoid any possible damage or accidents.

➤ Product Introduction

The K-9 Bulldog is an LED PAR 64 fixture with an aluminum shell. The Bulldog uses high power 8W RGBW 4-in-1 LED's. Each color can be independently controlled including dimmer, strobe, gradual change and fading. The fixture also includes slave functionality and DMX addressing.

➤ Packing list

- LED PAR 64 fixture
- 5' Data cable
- User manual

Safety Information

- No user serviceable parts inside. Speak with a skilled professional before attempting any repair.
- Disconnect from the power source before setting up or moving.
- Avoid direct eye exposure to the fixture when it is on.
- Make sure the power supply voltage is consistent with this light, rated at 110v/60hz
- This light is designed for indoor use. Working temperature should be lower than 100°F.
- The fixtures may be mounted in any position provided there is adequate room for ventilation. Make sure there are no flammable or explosive items with 2 feet of fixture.
- Grounding is important for proper fixture operation.
- If your Bulldog is in a continuous use environment with atmospheric particulates like fog, smoke or dirt, be sure to inspect and clean the fan with compressed air as necessary.

Fixture Diagram

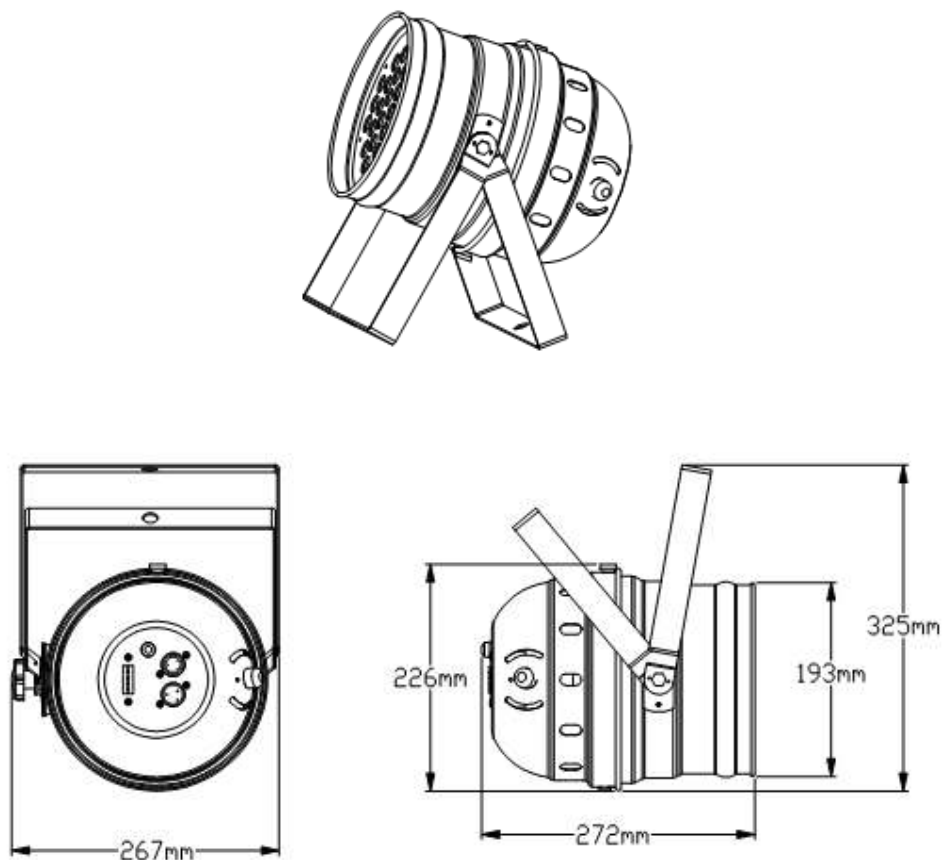

Bulldog LED PAR 64

Features

- High quality LED: low power consumption, bright 8 watt LEDs, even field, and long life
- Fully dimmable 0 – 100%
- Adjustable strobe rate
- DMX controlled, addressable from the LED display

- Auto run / sound activated / master slave / interconnected multi control
- Uses switching power supply to protect LEDs
- Lens degree: 25° or 45°
- DMX512 – Channel Modes – 3, 4, 5, or 8
- Body color: black (white optional)

DMX Control

8 Channel Mode

Channel	DMX Value	Control Function	Remarks	Priority
1	0-255	INTENSITY	Must use this channel to control dimming 0 to 100%	1
2	0-255	RED	0 to 100%	2
3	0-255	GREEN	0 to 100%	2
4	0-255	BLUE	0 to 100%	2
5	0-255	WHITE	0 to 100%	2
6	0-14 none	STROBE	Various strobe effects	3
	15-255 freq			
7	0-31	None		Must also use channel 1 plus colors on channels 2-5 for these effects.
	32-63	MACRO	Dark to bright	
	64-95	MACRO	Bright to dark	
	96-127	MACRO	Dark to bright to dark	
	128-159	MACRO	RGB color roll	Control speed with CH 8
	160-191	MACRO	Dark to bright to dark auto sequence	
	192-223	MACRO	Four color flash	
	224-255	AUDIO	Multi-color jump	Sound activated
8	0-255	MACRO SPEED	Works with channel 7 0 = slow, 100% = fast	4

5 Channel Mode

Channel	DMX Value	Control Function	Remarks	Priority
1	0-255	INTENSITY	Must use this channel to control dimming 0 to 100%	1
2	0-255	RED	0 to 100%	2
3	0-255	GREEN	0 to 100%	2
4	0-255	BLUE	0 to 100%	2
5	0-255	WHITE	0 to 100%	2

4 Channel Mode

Channel	DMX Value	Control Function	Remarks	Priority
1	0-255	RED	0 to 100%	1
2	0-255	GREEN	0 to 100%	1
3	0-255	BLUE	0 to 100%	1
4	0-255	WHITE	0 to 100%	1

3 Channel Mode

Channel	DMX Value	Control Function	Remarks	Priority
1	0-255	HUE	Selects primary light color. Orange = 0%, Red = 100%	2
2	0-255	SATURATION	Adjusts shade of color deep to light	3
3	0-255	INTENSITY	Adjusts Intensity of light output.	1

Display

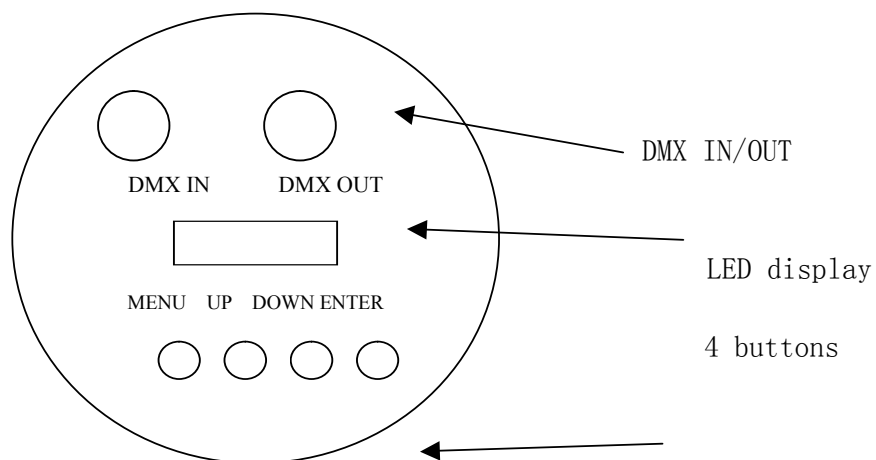

- MENU : access the menu or return to a previous menu option
- ENTER: select the current menu option
- UP: menu selection or parameter increments
- DOWN: menu selection or parameters decrease

Menu



MENU is used to access the menu or return to a previous menu option. It can not be used to select and store the current menu option. Press UP / DOWN to choose a desired menu item.

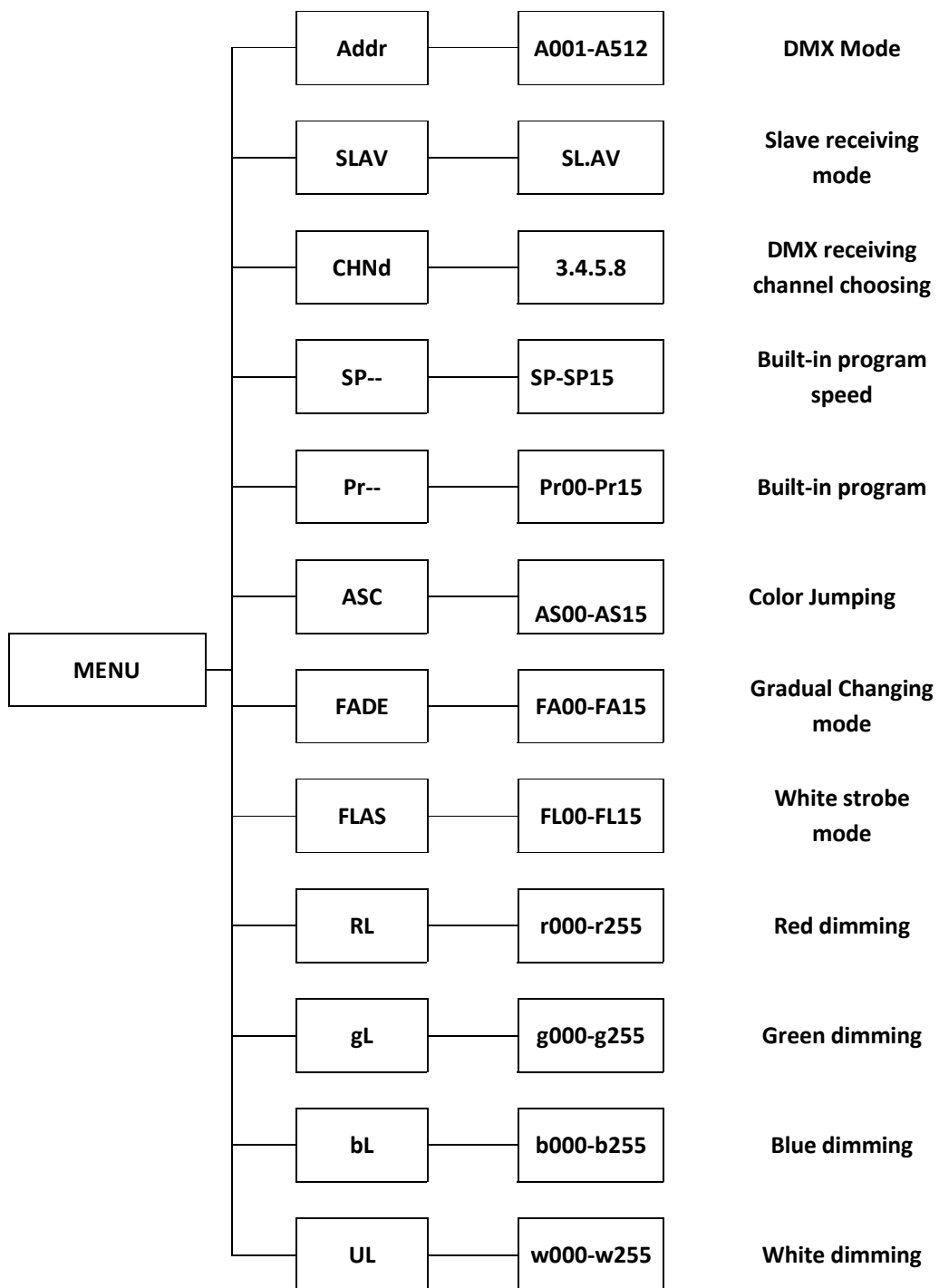

Press ENTER to access further menu settings or press enter to save the current setting.

For example, if you want to choose DMX mode A001, select as follows:

- Press MENU, go back to the initial setting
- Press UP / DOWN until “Addr” appears
- Press ENTER to select (the display will flash)
- Press UP / DOWN to change the address code to select A001
- Press ENTER to select and store the current menu options. DMX mode will be stored automatically and the screen will stop flashing.

3. Details of fixture presets (Pr- -)

- Press MENU, go back to the initial setting
- Press UP / DOWN until “Pr--“ appears
- Press ENTER to choose, the display will flash
- Press UP / DOWN to change the program code to select pr00
- Press ENTER to select and store the current menu options. DMX mode will be stored automatically and the screen will stop flashing.

Program Options:

Pr00:red;	Pr01:green	Pr02:blue	Pr03:amber
Pr04:cyan	Pr05:purple	Pr06:white;	Pr07:red+strobe;
Pr08:green+strobe	Pr09:blue+strobe;	Pr10:amber+strobe;	Pr11:cyan+strobe
Pr12:purple+strobe;		Pr13:white+strobe;	
Pr14:RGB jumping change;		Pr15: 7 colors continuously changing;	

Note: Pr7--- Pr15 Changes the content Of SP, adjust the speed of continuous color changes. SP00 is the fastest, SP15 is the slowest

➤ **Master/Slave**

Multiple fixtures can be operated simultaneously without a control board by connecting each fixture with DMX control cable and using one fixture as “Master” and the others as “Slave”. The “Master” fixture will then synchronize with the “Slave” units.

To use this feature, make sure there is nothing plugged into the “DMX IN” on the fixture “Master”. Daisy-chain from the “Master” “DMX OUT” to the “Slave” fixtures. Set the DMX address on every “Slave” unit to A001. Only one light within a group can serve as “Master”.

If the length of DMX data cables extend more than 180’ or there are more than 20 fixtures being used as “Slaves”, the DMX signal will need to be boosted.

Connecting Fixtures

➤ XRL cable:

Using 3-Pin XLR data cable, connect the male end to your console, and the female end to the “DMX IN” connector on your fixture. Using additional data cable, you can connect a string of fixtures by feeding from “DMX OUT” on one fixture to “DMX IN” on each additional fixture in the chain.

DMX signal must “daisy-chain”. The use of a “Y” adapter to split the signal will cause the fixtures to function incorrectly.

If the DMX 512 output on your control board has a 5-pin DMX connector, you will need a “5-pin male to 3-pin female DMX adapter” between your console and the first fixture.



XLR Pin Configuration
Pin 1 = Ground
Pin 2 = Data Compliment (negative)
Pin 3 = Data True (positive)

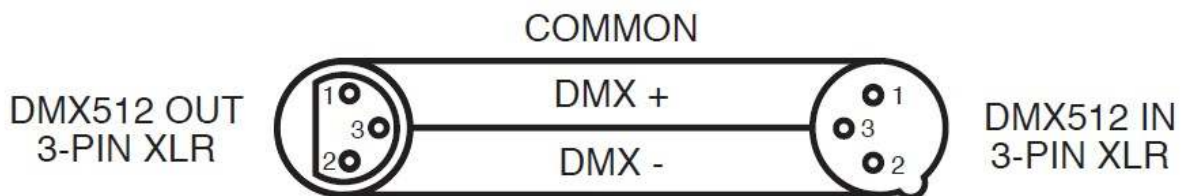

3-Pin XLR to 5-Pin XLR Conversion		
Conductor	3-Pin XLR Female (Out)	5-Pin XLR Male (In)
Ground/Shield	Pin 1	Pin 1
Data Compliment (- signal)	Pin 2	Pin 2
Data True (+ signal)	Pin 3	Pin 3
Not Used		Do Not Use
Not Used		Do Not Use

Optional Accessories

Item	Part #
5 Pin to 3 Pin Data Cable Adapter	WIR 5PM3PF
C-Clamp	ACC CC
Safety Cable	HRD SAFE
3 Pin Data Cables (10')	WIR 3010

Technical Specification

- Input voltage: 115V 60Hz
- Output voltage: DC24V
- Power Consumption: 148W
- Lamp Type: High Power 8W LED
- Lamp Spec: RGBW 4-in-1 LED 8W (18PCS)
- Constant current: 500mA
- Refresh Frequency: > 400HZ
- Life span: 50000~100000hours
- Control Signal: DMX512, sound activated, auto run
- Control mode: stand alone/ DMX/ master and slaver
- Channel: 3、4、5、8CH
- Color effect: R、G、B、W color mixing
- Function Effect: dimmer, strobe, gradual change
- Beam Angle: 25°,45°
- Cooling mode: Fan and Convection
- Net Weight: 7 lbs



K-9 LIGHTS